

1. GENERAL INFORMATION

Valid standards for the application of heat meters: EN 1434, parts 1 – 6; the Measuring Instruments Directive 2014/32/EU.

For the selection, installation, commissioning, monitoring and maintenance of the instrument observe the standard EN 1434 part 6, as well as the verification regulations any relevant national verification regulations in other countries.

The technical regulations for electrical installations must be observed.

This product fulfils the requirements of the European Council Directive on Electromagnetic Compatibility (EMC Directive) 2014/30/EU.

The identification plate of the instrument and the seals must not be removed or damaged – otherwise the guarantee and the approved application of the instrument are no longer valid!

2. APPLICATION AND FUNCTION

Pulsar M compact heat/cooling meter is used for heat/cooling energy in closed systems



3. CONTENTS

Pulsar M compact heat/cooling meter consists of a flow sensor, an integrator (calculator) and a pair of temperature sensors.

4. INSTALLATION

The prescriptions related in the standard EN1434-6 must be respected when the Pulsar M is installed.

The integrator is parameterized for installation on the «cold» pipe side or on the «hot» pipe side.

Parameterization must be specified with the order. It is possible to change parameter «installation pipeline» only one time before start an operation. Sign  on LCD means installation on the «cold» pipe side, sign  means installation on the «hot» pipe side. It is not possible to change parameter «installation pipeline» after starting normal operation.

The heat meter must be fitted on the «cold» or «hot» pipe side of the installation in compliance with the chosen configuration.

Place the flow meter correctly according to the direction of the fluid (an arrow -> can be seen on the flow meter).

Avoid fitting in a position which may cause an air bubble to build up inside the flow meter.

The flow meter must be fitted between two shutoff valves. Waterproof will be checked at the various mounting points.

If additives are added to the water, the user must ensure the compatibility of the materials used in the flow meter which are in contact with these additives.

The following steps must be respected:

- Flush out the installation pipes carefully in compliance with the DIN/EN standard specification.

- Close the shutoff valves before and behind the meter.

- Open the drainage valve to reduce the pressure and discharge the water contained in the pipe between the two shutoff valves.

- Place a gasket on each side of the flow meter. Only use appropriate new gaskets.

- Make sure that the gaskets are carefully positioned in relation to the water pipe and flow meter unions.

- Tighten the fixing nuts firmly by hand. Then tighten up to the mechanical end stop using a mounting tool.

- Check the waterproof of the meter placed under pressure.

The pipes are generally free from air before the installation is brought into service. Final commissioning must be performed and documented.

The integrator can be separated from the flow meter and fixed against a wall. If possible, install the integrator above the flow meter.

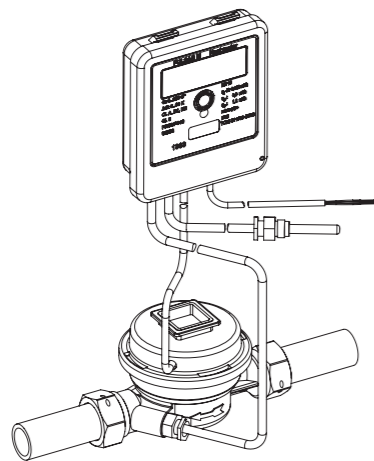

Mounting the temperature sensors

One temperature sensor is installed in the flow meter and sealed. Another one temperature sensor must be mounted in the pipe «opposite» to the Pulsar.

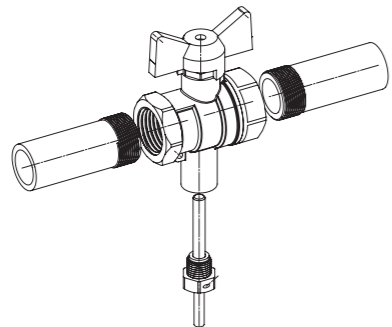

Example: If the flow meter is installed on the warm side (Hot Pipe), another one temperature sensor will be mounted in the cold side (Cold Pipe).

The temperature sensor has male brass nut with thread M10x1 and can be mounted on the T tube or ball valve with hole for temperature sensor.

Slide the o-ring off the temperature sensor and insert it to the bottom of threaded opening of the T tube or ball valve

Insert the temperature sensor into the brass fitting (T tube or ball valve).

Tighten the M10x1 mm male nut until stumbled on the brass fitting.

The Pulsar is delivered with a cable length of 1.5 m for the temperature sensors. The temperature sensor cables must be neither shortened nor lengthened.

6. TECHNICAL DATA SHEET

6.1 Flow sensor

Nominal diameter	DN15	DN15	DN15	DN20	DN20
Minimum flow q_i , m ³ /h (horizontal/vertical)	0,012/0,24	0,02/0,04	0,03/0,06	0,03/0,06	0,05/0,10
Nominal flow q_p , m ³ /h	0,6	1	1,5	1,5	2,5
Maximum flow q_s , m ³ /h	1,2	2	3	3	5
Thread	G3/4B	G3/4B	G3/4B	G1B	G1B
Length, mm	110	110	110	130	130
Dynamic range q_i/q_p	1:50 (1:25 for vertical installation)				
Ambient temperature, C	5..55				
Pressure loss at q_p , bar	< 0,2				
Accuracy class (EN1434)	3				
Nominal pressure, bar	16				
Liquid specification	water				
Direction of flow	one direction				
Temperature range, C	0..90				
Installation	Return flow/forward flow horizontal/vertical				
Sensitivity to irregularity class	U3, D3				

6.2 Calculator, temperature sensors

Temperature range, C	0..90	Display	LCD, 8 digits + icons
Temperature difference range, K	3-90	Units	MWh, kWh, GJ, Gcal
Temperature resolution, K	0,01	Inputs (optional)	4 pulse type for external meters
Ambient temperature, C	5..55	Interfaces (optional)	Pulse, M-Bus, RS-485, optical (IR), WM-bus, LoRa
Protection	IP65	Power supply	3,6 V, Lithium, 10 years
Environmental class	C	Temperature sensors	Pt1000
Electromagnetic class	E1 and E2	Data history in EEPROM memory	60 months, 184 Days, 1488 hours
Mechanical class	M1		

5. START AN OPERATION

Open the shut off valves slowly. Check that there are no leaks.

Check the following points:

- Are all shut-off valves open?
- Is the meter of the right size?
- Is the heating (heating/cooling) system clear (dirt filters not clogged)?

- Is the temperature sensor installed in the flow sensor correctly sealed to the flow sensor?

- Does the directional arrow on the connection piece / flow sensor match the actual direction of flow?

- Is a flow volume displayed?

- Is a plausible temperature difference displayed?

When the meter is functioning properly, attach the seals to the exterior temperature sensors and the flow sensor (required to protect against manipulation).

7. SEALING

The Pulsar heat meters are tamper-evident sealed with self-adhesive seals to prevent unauthorized access to the electronic system – see the figure below.

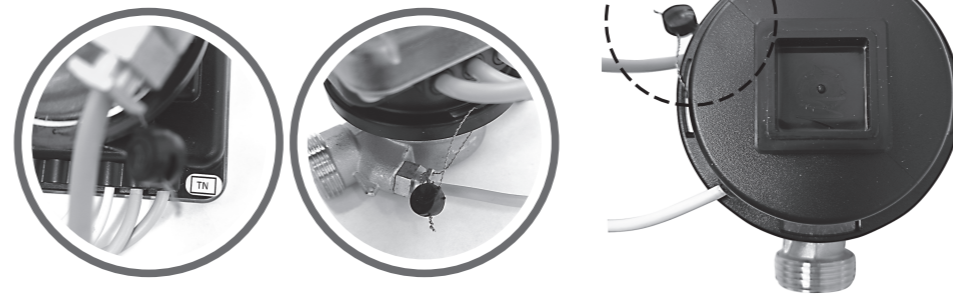

8. INTERFACES AND OPTIONS

Several communication interfaces are available.

8.1 Pulse output (open collector).

One pulse means 0,001 MWh (other scale factors are possible).

Pulse duration 125 ms, switching I_{max} 50 mA, switching U_{max} 24V. Pin assignment: brown – plus; white – minus.

8.2 RS-485 used for current and history data reading.

Pin assignment: white – minus; brown – plus (7-20 V, 10 mA); yellow – RS-485 A; green – RS-485 B.

Software TestAll and software ServerPulsar used to read data.

Pin assignment when RS-485 and 4 pulse inputs is in one cable: grey – input 1; pink – input 2; blue – input 3; red – input 4; white – minus; brown – plus (7-20 V, 10 mA); yellow – RS-485 A; green – RS-485 B.

8.3 M-Bus used for reading current data.

Pin assignment: white – M-Bus; brown – M-Bus.

Pin assignment when M-Bus and pulse inputs are in one cable: grey – input 1; pink – input 2; blue – input 3; red – input 4; white – ground; yellow – M-Bus A; green – M-Bus B.

Additional technical specifications

Maximum voltage M-Bus	42 V
Minimum voltage M-Bus	24 V
Maximum ripple voltage	200 mV; EN 13757-2_2004; 4.3.3.6
Maximum voltage potential differences	2 V

Technical data M-Bus

Primary address	0 (factory setting)
Baud rate	2400; 9600
Number of possible read-outs	unlimited

8.4 Optical (Infrared) interface.

For communication with optical interface optocoupler is necessary. The optocoupler is available as accessory equipment.

The optical infrared interface will be activated by automatically sending a header (according to EN 13757-3). Baud rate: 2400 baud.

Then you can communicate with the meter for 60 seconds. Afterwards the display is deactivated.

8.5 WM-Bus

General information about the radio interface: Installation of radio components between or behind heating pipes, or the presence of other bulky metallic obstacles directly over or in front of the housing must be avoided. The transmission quality (range, telegram processing) of radio components can be negatively influenced by instruments or equipment with electromagnetic emissions, such as telephones (particularly LTE mobile radio standard), wi-fi routers, baby monitors, remote control units, electric motors, etc. In addition, the construction of the building has a strong influence on the transmission range and coverage. Furthermore, when using installation boxes (substations) they must be equipped with non-metallic covers or doors.

Technical data radio

Frequency	868 MHz
Transmission power	up to 12 dBm
Selectable modes	S1 / T1
Telegrams	- short telegram in conformity to AMR (OMS-Spec_Vol2_Primary_v301 and _v402): energy (heat, pulse input 1 to pulse input 3), total volume, power, information message, outlet flow - long telegram for walk-by read-out: energy (heat energy, pulse input 1 to pulse input 3), total volume, information message, 12 monthly values (compact mode)

Radio configuration

Parameter	Possible settings	Factory setting (Battery lifetime, estimated: 6 years)
Mode	S1 / T1; unidirectional	T1 (unidirectional)
Transmission interval	240 seconds	240 seconds
AES-128-Encryption	- not encrypted; - encrypted according to MODE 5 - Master Key - key per instrument	- Master Key
Type of telegram	- short telegram in conformity to AMR (OMS-Spec_Vol2_Primary_v301 and _v402) - long telegram for walk-by read-out	long telegram (walk-by)

8.6 LoRa

Technical data radio

Specification LoRaWAN	V. 1.0.3
Frequency	RU 864 MHz; EU 868 MHz
Transmission power	max 14 dBm
Radio cycles	typically 8 hours
Activation type	OTAA
Activation of radio	Always on / optional activation device

9. DIMENSIONS

DN	15	20
D, MM	G3/4	G1
L, MM	110	130

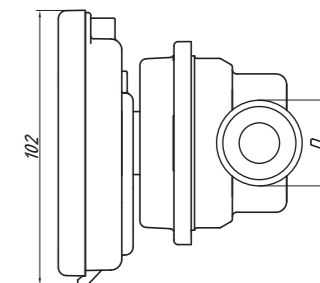
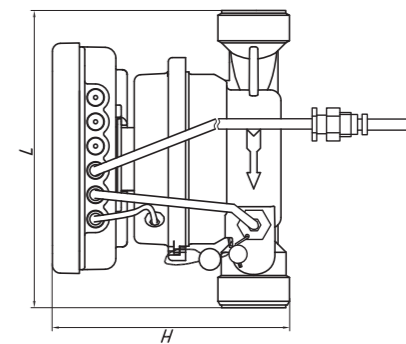

10. PRESSURE LOSS DIAGRAM

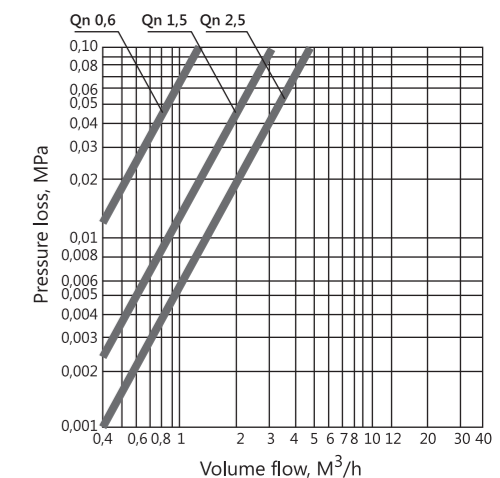

11. DISPLAY

MENU

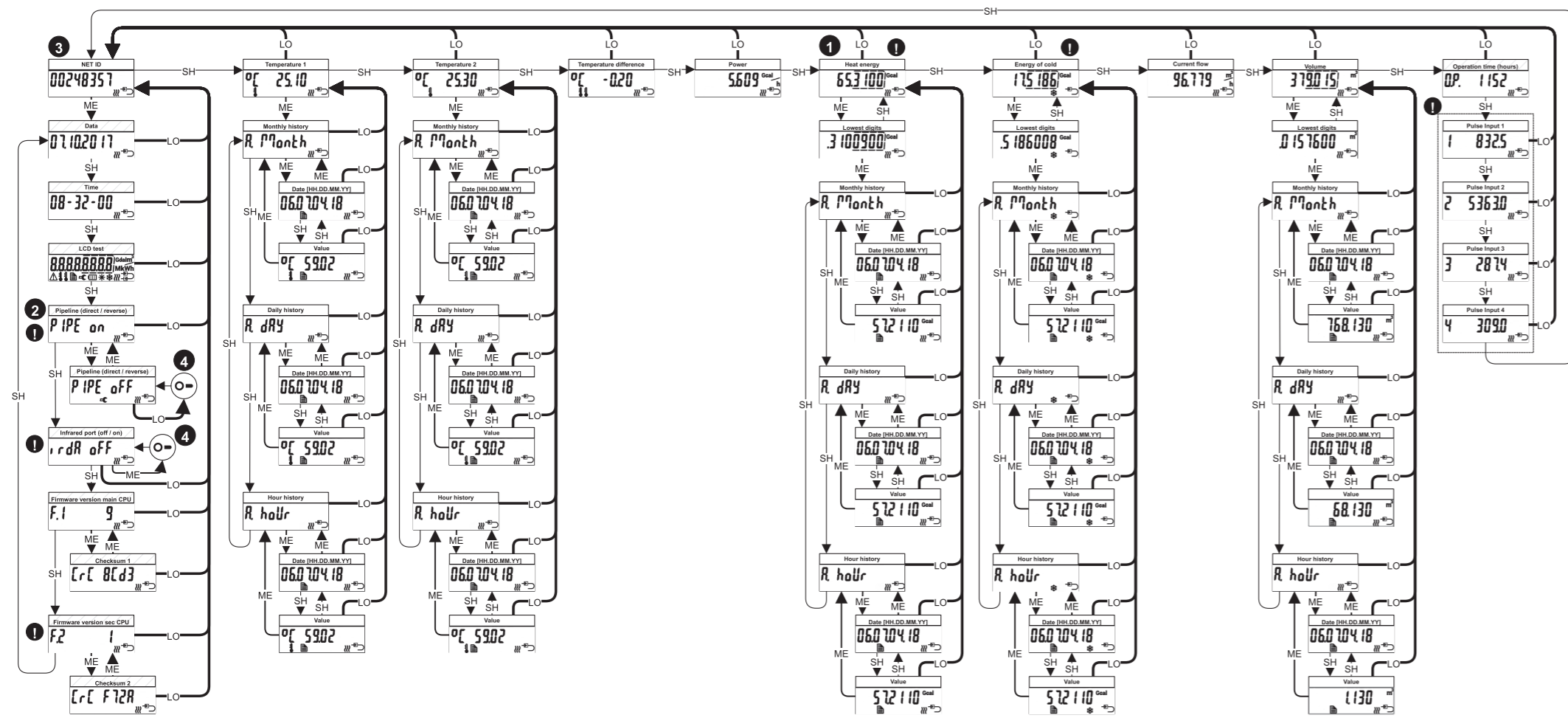

- 1 when no button touch for 60 seconds, heat energy displays
- 2 - installation in the supply pipe
- 2 - return pipe installation
- on - there is the possibility of switching feed / reverse
- off - no possibility of switching feed / reverse
- 3 - heat meter
- cold counter
- combined heat / cold meter
- 4 switching direct/return pipe
- 1 may not be available depending on the version of the device

- SH— SHORT touch button for less then 0,7 sec
- ME— MEDIUM touch button for more then 0,7 sec but less then 2,5 sec
- LO— LONG touch button for more then 2,5 sec

12. WARRANTY AND SERVICING

The reliable operation of the heat meter is guaranteed for a warranty period specified in the enclosed warranty certificate, provided that operation of the heat meter meets the requirements provided in this document. The warranty does not cover any damage caused by improper shipping or operation. The user's warranty rights will be void and null if the product is repaired without authorization by the manufacturer.

The warranty is void and null when the following is found:

- repairs made by personnel unauthorized to perform warranty service
- unauthorized removal of tamper seals
- modifications or al of the product design
- installation or operation against the intended use of the product specified in the operating manual
- damage to the counter enclosure.

EU DECLARATION OF CONFORMITY

1. **Product type/model:** Mechanical heat meter – compact, type Pulsar M
2. **Name and address of the manufacturer:** Teplovodokhran Ltd., Novaya str. 51 v, Ryazan
3. **This declaration of conformity is issue under the sole responsibility of the manufacturer.**
4. **Object of declaration:** Mechanical heat meter – compact
5. **Above mentioned object is in conformity with relevant Union harmonization legislation:**
Directive No. 2014/32/EU (MID)
Directive No. 2014/30/EU (EMC Directive)
6. **References to the relevant harmonized standards or normative documents:**
EN 1434:2015 Heat meters
OIML R 75:2006 Heat meters
7. **Notified body**

Name and number of NB	Performed	Issued the Certificate No.
Czech Metrology Institute, NB 1383 Okruzni 31, 638 00 Brno Czech Republic	EU type certification in accordance with Module B of Directive No. 2014/32/EU	TCM 311/18-5583
Czech Metrology Institute, NB 1383 Okruzni 31, 638 00 Brno Czech Republic	Certification of production, final product inspection and testing in accordance with Module D of Directive No. 2014/32/EU	0513-SJ-A002-19

8. **Addition information:**
Signer for and on behalf of *Vladimir Kozlov, director*
Place and date of issue In Ryazan, on 14th May 2021

Version 02-2021

Mechanical thermal energy meter Pulsar M

Installation and operation instructions

CE
MID Certificate
TMC 311/18 - 5583

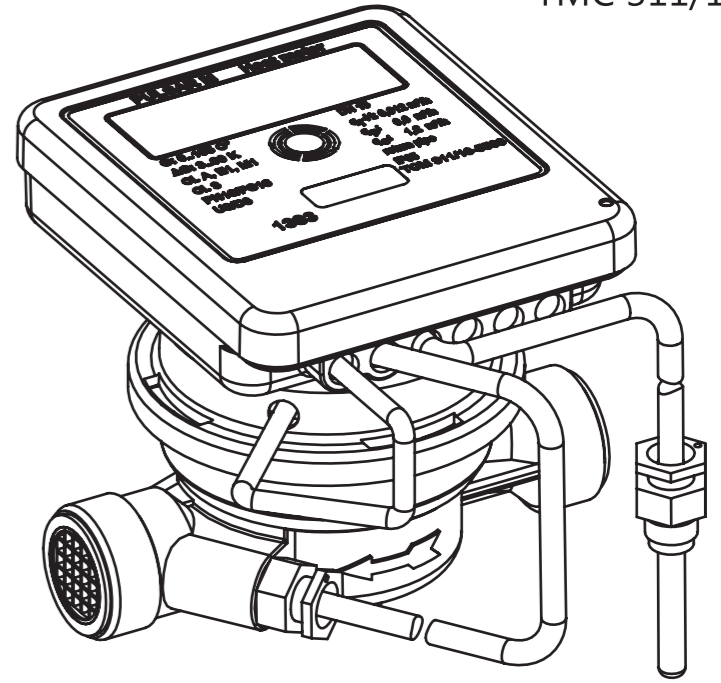

TEPLOVODOKHRAN LTD
Address: Novaya str, 51v, Letter «J»
nonresidential room H2 Ryazan, 390027 Russia
+7 (4912) 24-02-70, sale@pulsarm.ru

